

Vacuum Oven

SVO-5-VC

PART ID: CTVR522-H

CASCADE™
TEK

Capacity	4.88 cu.ft. (138 liters)
Interior Dimensions (W x D x H)	18" x 26" x 18" 457 x 660 x 457 mm
Exterior Dimensions (W x D x H)	28.8" x 46.5" x 64.6" 732 x 1182 x 1640 mm
Unit Weight	760 lb (345 kg)
Shipping Weight	1078 lb (489 kg)
Shelves	3 Anodized Aluminum Standard, 6 Maximum
Maximum Weight Per Shelf	50 lb / 22.7 kg
Permitted Total Load	200 lb / 90.7 kg
Standard Door Gasket	Viton Standard
Access Port	1 -KF25
Controls	Watlow F4T
Warranty	2 Year Limited Warranty
Interior Construction	300 series stainless steel
Exterior Construction	20 gauge steel, powder coated
Wall Clearance, Each Side	6.0" (152 mm)
Wall Clearance, Rear	12.0" (305 mm)
Vertical Clearance	12.0" (305 mm)
Electrical, 50/60Hz, AC, 1Ø	
Voltage	220V-240V
Power Current (Max Draw) Amps	20
Nominal Power (watts @150°C)	680
Direct Hardwired	✓
Energy Consumption (kWh/day)	
At 80°C	9.22
At 150°C	16.34
At 220°C	26.3
Temperature Range	
	Ambient 10°C to 220°C
Heat-Up Time — Minutes to 80°C	68
Heat-Up Time — Minutes to 150°C	125
Heat-Up Time — Minutes to 220°C	177
Operation Vacuum Range	
	760 Torr to Less than 10 mTorr
Temperature Uniformity	+/- 6% of Set Point
Temperature Stability	+/- 0.2°C @ 150°C
Vacuum Display Range	1100 to 0.1 mTorr



MADE IN
USA



We reserve the right to alter specifications at any time.

0740648 6/22

Contact Cascade TEK
sales@casca detek.com • casca detek.com • +1-971-371-4096

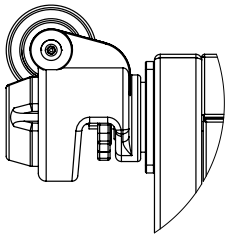

OPTIONAL CASTERS ADD
0.75 IN TO OVERALL HEIGHT
DETAIL A
SCALE 1 : 4

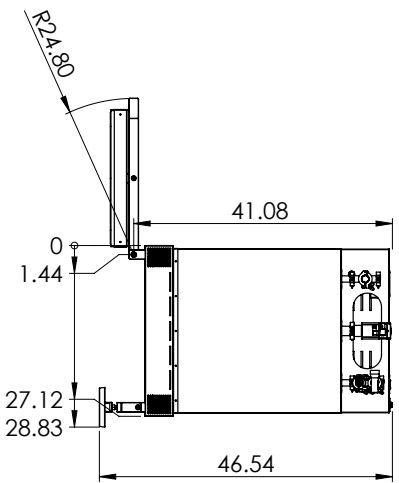

Top View

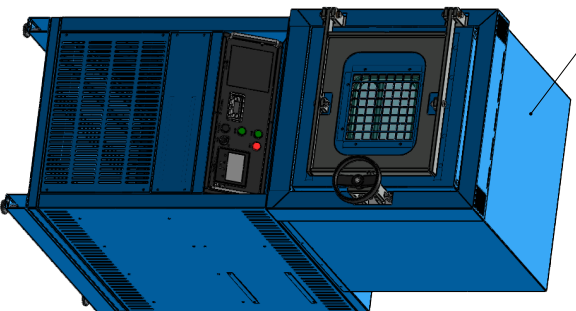

EXTERIOR MATERIAL:
COLD ROLLED STEEL
POWDER COATED

INTERNAL MATERIAL:
300 SERIES STAINLESS STEEL

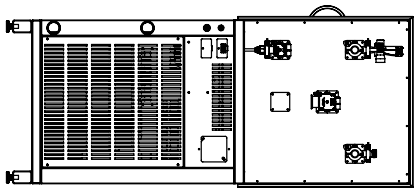

Back View

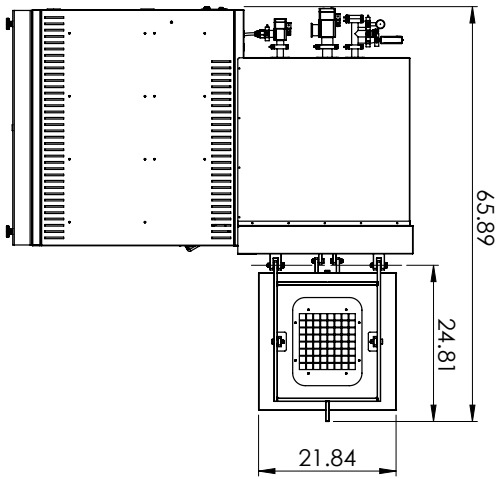

Side View

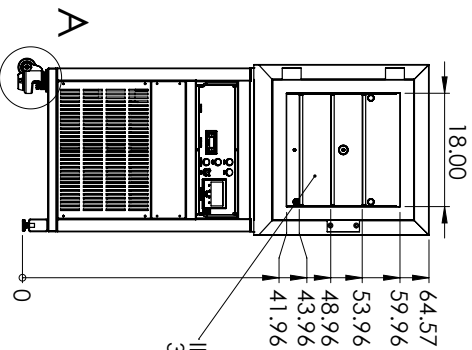

Front View (Door Not Shown)



CASCADE

Cascade TEK Solutions, LLC
300 N 26th Ave
Cornelius, OR 97113

PROPRIETARY AND CONFIDENTIAL
THE INFORMATION CONTAINED IN THIS
DRAWING IS THE SOLE PROPERTY OF
CASCADE TEK SOLUTIONS, LLC. IT IS TO BE
USED ONLY FOR THE PROJECT AND IN
PART OR AS A WHOLE WITHOUT THE
WRITTEN PERMISSION OF Cascade TEK
SOLUTIONS, LLC.

DATE	NAME	DRAWN
1/15/2020	GT	GT

MODEL:

SVO-5-VC

SIZE	DWG. NO.	REV
B	9101005	A

SCALE: 1:20 WEIGHT:

SHEET 1 OF 4